



"Your Direct Source for Condition Monitoring, Test & Measurement"

www.reliabilitydirectstore.com

2911 South Shore Blvd, Suite 170, League City, TX USA 77573 Phone: 281-957-5283 Fax: 281-334-4255

MONARCH INSTRUMENT

Instruction Manual



SPS-5/115



SPS-5 and SPLS-5 Series Self-Powered Sensors TTL Pulse Output



Safeguards and Precautions



1. Read and follow all instructions in this manual carefully, and retain this manual for future reference.
2. Do not use this instrument in any manner inconsistent with these operating instructions or under any conditions that exceed the environmental specifications stated.
3. This instrument is not user serviceable. For technical assistance, contact the sales organization from which you purchased the product or Monarch Instrument directly.

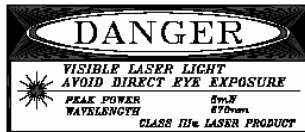

LIMITED WARRANTY

SELLER warrants hardware products to be free from any defect in materials or workmanship for a period of one (1) year from date of shipment to BUYER. SELLER's entire liability and BUYER's sole and exclusive remedy resulting from any defect in workmanship or material in the hardware product covered by this limited warranty shall be limited to and fully discharged by the SELLER's option of replacement or repair of such item without charge. The limited warranty provided in this clause is in lieu of all other warranties, expressed or implied, arising by law or otherwise. ALL IMPLIED WARRANTIES OF MERCHANTABILITY AND FITNESS FOR A PARTICULAR PURPOSE ARE EXCLUDED. This limited warranty shall not be modified except by an arrangement signed by both parties specifically referencing this clause.

SELLER warrants that any software supplied will operate in accordance with the documentation or manual supplied therewith in all material respects when used in strict compliance with such documentation or manual. Notwithstanding the foregoing, BUYER acknowledges that, since software is complex and therefore may have defects, BUYER's sole and exclusive remedy for any such defects or breach of this warranty shall be to require SELLER, within a reasonable period of time, to provide all reasonable programming services to correct programming errors in the software. Except as provided above SELLER MAKES AND BUYER RECEIVES FROM SELLER NO EXPRESS OR IMPLIED WARRANTIES OF ANY KIND WITH RESPECT TO ALL OR ANY PORTION OF SOFTWARE AND BUYER HEREBY AGREES AND ACKNOWLEDGES THAT IT ACCEPTS THE SOFTWARE IN 'AS IS' CONDITION. SELLER HEREBY EXPRESSLY EXCLUDES ANY IMPLIED WARRANTIES OF MERCHANTABILITY OR FITNESS FOR A PARTICULAR PURPOSE WITH RESPECT TO THE SOFTWARE. BUYER agrees that any specific right or remedy granted to BUYER hereunder with respect to any breach or default by SELLER shall be in lieu of all other rights and remedies otherwise available to BUYER at law or in equity as the result of such breach or default, regardless of whether based on contract, tort, strict liability, or other theory of liability.

IN NO EVENT SHALL SELLER BE LIABLE FOR ANY SPECIAL, INDIRECT, INCIDENTAL, CONSEQUENTIAL, OR PUNITIVE LOSSES OR DAMAGES (INCLUDING, BUT NOT LIMITED TO, LOSSES OR DAMAGES FOR ANY LOST PROFITS OR LOST DATA) AS THE RESULT OF ANY BREACH OR DEFAULT BY SELLER WITH RESPECT TO THE HARDWARE OR SOFTWARE, EVEN IF SELLER HAS BEEN ADVISED OR MADE AWARE OF THE POSSIBILITY OF ANY SUCH LOSSES OR DAMAGES AND REGARDLESS OF WHETHER THE CLAIM IS BASED ON CONTRACT, TORT, STRICT LIABILITY, OR OTHER THEORY OF LIABILITY.

This limited warranty does not extend or apply to consumables (including, but not limited to, lamps and batteries, if applicable) or equipment, instruments or accessories which are warranted separately by the original manufacturer of these items.

TABLE OF CONTENTS

INTRODUCTION	1
COMPONENT SPECIFICATIONS	2
SPS-IM Interface Module	2
ROS-5P Remote Optical Sensor	3
RLS-5P Remote Laser Sensor	4
SPS CONFIGURATIONS	5
SPS-5 Series	5
SPLS-5 Series	5
FUNCTIONS AND OPERATION	6
SPS Interface Module	6
Connections	6
Controls	7
Recharging the Batteries	7
SPS-5 Series - SPS with Remote Optical Sensor	8
ROS-5P	8
Operating the SPS-5 as a triggering source	8
SPLS-5 Series - SPS with Remote Laser Sensor	9
RLS-5P	9
Operating the SPLS-5 as a triggering source	11
Operational Check	12
SENSORS / OPTIONS AND ACCESSORIES	13

INTRODUCTION

SPS and SPLS **Self Powered Sensors** are self-contained, rechargeable battery powered devices for developing a TTL compatible one pulse per revolution output for triggering external equipment such as vibration analyzers, spectrum analyzers, stroboscopes, data acquisition equipment, tachometers, balancers, waveform analyzers and magnetic tape recorders.

The **SPS-5 Series** is comprised of the **SPS-IM Interface Module** which provides power to a sensor and couples the sensor to a BNC output; an input sensor with a visible red LED light source (**ROS-5P**); and a battery recharger.

The **SPLS-5 Series** is comprised of the **SPS-IM Interface Module** which provides power to a sensor and couples the sensor to a BNC output; a remote laser light input sensor (**RLS-5P**); and a battery recharger.

An optional infrared light source (**IRS-5P**) or amplified magnetic sensor (**MT-190P**) may also be combined with the **SPS-IM Interface Module** when appropriate. (See separate instructions for these configurations.)



ROS-5P
Remote Optical Sensor



RLS-5P
Remote Laser Sensor



SPS-IM
Self-Powered Sensor
with R-5 Recharger



IRS-5P
Infrared Sensor



MT-190P
Magnetic Trigger Sensor

SENSORS / OPTIONS AND ACCESSORIES

ROS-5P	Remote Optical Sensor with 8 foot cable and mounting bracket
RLS-5P	Remote Laser Sensor with 8 foot cable and mounting bushing on base
IRS-5P	Infrared Sensor with 8 foot cable for use without reflective target at 0.5 inch gap (5 to 500,000 RPM)
MT-190P	Magnetic Trigger Sensor/Amplifier with 8 foot cable - 0.250 gap, 2" long x 5/8"-18NF
EC-25P	25 foot Extension Cable for remote sensors with male 1/8" [3.5 mm] phone plug to female 1/8" [3.5 mm] connector
T-5	Reflective Tape, 5 foot [1.5 m] roll, 1/2 inch [13 mm] wide
T-5WP	Waterproof Reflective Tape (honeycomb pattern), 5 foot [1.5 m] roll, 1 inch [25 mm] wide
B-4	Four "AA" Rechargeable NiCad batteries
R-5	Recharger, 115 Vac - 50/60 Hz
R-6	Recharger, 230 Vac - 50/60 Hz
CA-SPS12	Cable assembly with tinned leads for 5-15 Vdc operation

13

ROS-5P Remote Optical Sensor

Operating Envelope:	Up to 3 feet [0.9 m] and 45° from reflective target
Speed Range:	1 to 250,000 RPM
Operating Temp:	-10° F to 250° F [-23° C to 121° C]
Illumination Source:	Visible red LED, 5 Vdc @ 30 mA
Output Signal:	5 to 0 Vdc TTL compatible pulse (open collector with 4.7 k pull up to 5 Vdc)
On-Target Indicator:	Green LED on end cap
Lens:	Acrylic plastic
Dimensions:	Threaded Tube - 2.90" L x 0.625" diameter [M16 x 1.5 x 74 mm] supplied with two M16 jam nuts and slotted aluminum mounting bracket (2" x 2" x 0.80")
Material:	303 Stainless steel
Cable Length:	8 feet [2.5 m] Standard
NOTE:	Optional longer cables lengths include 15, 30 or 50 feet [4.6, 9.2 or 15 m].

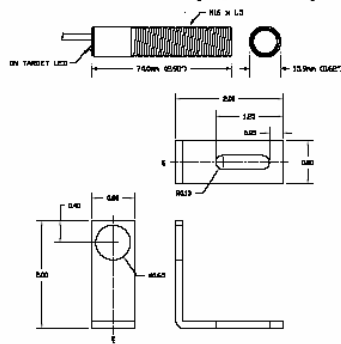

3

COMPONENT SPECIFICATIONS

SPS-IM Interface Module

Internal Batteries:	4 'AA' Nickel Cadmium 1.2 Vdc each, total 4.8 Vdc
Capacity:	600 mAh
Operating Interval:	8 hours typical from internal batteries
Continuous Operation:	115 Vac or 230 Vac using R-5 or R-6 recharger/ power supply, or CA-SPS12 cable for 9-13 Vdc
Charge Rate:	50 mA typical
Charge Time:	16 hours
Output:	TTL compatible pulse, Inverted (0 to 5 Vdc) or Non-Inverted (5 to 0 Vdc) – switch selectable. Open collector with 4.7 kΩ pull - up to 5 Volts in Inverted mode, passes sensor signal straight through in Non-Inverted mode (see sensor specifications)
Current Draw:	76mA with 10 kΩ load (operational)
Output Connector:	BNC Connector (female)
Operating Temp:	32° F to 122° F [0° C to 50° C]
Dimensions:	5.0" x 2.5" x 1" [127 mm x 64 mm x 25 mm]
Weight:	10 oz. [283 grams]

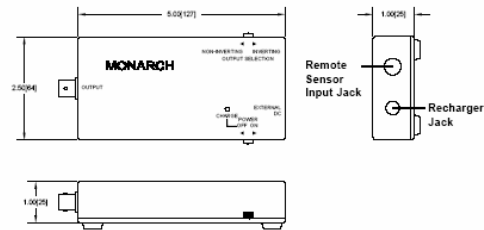

2

driving a hundred feet of coax cable. Be sure to select the direction (0 to 5 Vdc or 5 to 0 Vdc) of this signal to provide the required polarity of the leading edge to properly trigger the connected equipment.

When measurements are completed, immediately turn the "Power" switch OFF and close the shutter over the laser.



CAUTION:
Avoid direct eye exposure to the laser beam.

Operational Check

Correct operation of any SPS Self Powered Sensor can be checked at any time by aiming the sensor at a fluorescent light and observing 7200 ±2 counts on the instrument connected to the BNC output.

NOTE: In countries with a 50 Hz. Power line frequency, the instrument connected to the BNC output will read 6000 ±2.

12

Controls

The Laser Sensor can detect small changes in reflective light due to color or contrast changes, holes or slots in the surface or reflectivity of the subject. The actual sensing distance varies, and may be adjusted using the "Sensitivity" adjustment control on the Laser Sensor. For maximum distance, it is advisable to use areas of high contrast or reflective tape on the rotating object.

Operating the SPLS-5 as a triggering source

Mount the RLS-5P securely on a tripod or fixed surface that can be moved for alignment purposes. For ease of alignment and reliability of operation, locate the sensor as close to the target as practical (but not within one inch). It is recommended that you aim the sensor at a slight angle from perpendicular (approximately 15 degrees) to ensure the sensor will detect only reflected pulses.

Turn the "Power" switch on the SPS-IM module to the ON position. Open the shutter on the Laser Sensor. Observe that the LASER ON LED illuminates.



CAUTION:
Avoid direct eye exposure to the laser beam.

Visually align the laser light with the target, ideally with the moving equipment stopped. Start the equipment, and further adjust the manual alignment and the "Sensitivity" control to maximize the brightness of the green "TARGET" LED. This will be the condition of optimum performance.

The pulse signal on the connector marked "Output" provides a sharp leading edge for reliable and repeatable triggering of the connected device. This output has a low impedance (50 ohms) and is capable of

RLS-5P Remote Laser Sensor

Laser: Visible red laser diode (670 nm), 5 mW peak power
Excitation Voltage: 4.8 to 8 Vdc @ 75 mA
Classification: Normal Mode: Class IIIa Laser Product
 Setup Mode: Class II Laser Product
Beam Divergence: 1.5 mrad typical
Beam Diameter: 4 x 0.6 mm
Laser Diode Life: 100,000 hours typical
Operating Range: Up to 50 feet [15 m] with reflective target
Min. Trigger Duration: 50 usec (equiv to 250,000 RPM)
Output: 5 to 0 Vdc TTL compatible pulse (open collector with 4.7 k pull up to 5 Vdc)
Connector: Circular DIN Mak 4100 Socket
Indicators: LASER ON, SET UP and ON-TARGET LEDs
Sensitivity Adjust: Single turn trimmer control knob on top panel
Modes: Normal: Adjust sensitivity and distance from target
 Set Up: Set up for reduced power (factory preset)
Dimensions: Length: 5.5" [141 mm] including laser nosepiece
 Body: 4.4" x 2.4" x 1.2" [113 mm x 62 mm x 31 mm]
Weight: 10 oz. [283 grams]
Mounting: ¼ -20 UNC Bushing in base of housing for tripod mount or customer supplied bracket (can also be used to ground the Remote Laser Sensor)
Temperature: Operating: -5° F to 122° F [-20° C to +50° C]
 Storage: -25° F to 140° F [-30° C to +60° C]
Humidity: 90% RH non-condensing



11

4

SPS CONFIGURATIONS

All SPS models consist of the SPS-IM Interface Module, an input sensor, and a means of accessing external power. The components of each configuration are shown below.

SPS-5 Series - SPS with Remote Optical Sensor

Model	Interface Module	Input Sensor	External Power Source
SPS-5/115	SPS-IM	ROS-5P	R-5 Recharger/Power Supply (115 Vac)
SPS-5/230	SPS-IM	ROS-5P	R-6 Recharger/Power Supply (230 Vac)
SPS-5/12	SPS-IM	ROS-5P	CA-SPS12 Cable with tinned leads

SPLS-5 Series - SPS with Remote Laser Sensor

Model	Interface Module	Input Sensor	External Power Source
SPLS-5/115	SPS-IM	RLS-5P	R-5 Recharger/Power Supply (115 Vac)
SPLS-5/230	SPS-IM	RLS-5P	R-6 Recharger/Power Supply (230 Vac)
SPLS-5/12	SPS-IM	RLS-5P	CA-SPS12 Cable with tinned leads

Laser Sensor be placed at a slight angle (approximately 15 degrees) from perpendicular, so that the Laser Sensor will detect only the reflected pulses from the target. The Laser Sensor should be at least 1 inch [25 mm] and may be up to 50 feet [15 meters] from the reflective tape target, provided that the "Sensitivity" adjustment is set properly (see below). The Laser Sensor is equipped with a green LED On-Target Indicator which will blink at the input frequency when properly aimed and adjusted for "Sensitivity".



CAUTION:
Avoid direct eye exposure to the laser beam.

There is a mechanical sliding shutter on the Laser Sensor that can be used to block the laser light for safety purposes.

NOTE: Open the shutter completely when using the Laser Sensor and close the shutter when it is not in use.

Indicators

There are three light emitting diodes (LED's) on the Laser Sensor which provide the following indications:

LASER ON: Green LED. When the Sensor is first powered up, there is a delay of a few seconds before the laser beam comes on. During this period, the "LASER ON" LED blinks. When the Laser comes on, the LED remains lit.

SET UP: Red LED. Factory use only.

TARGET: Green LED. Indicates that the Laser Sensor is receiving a reflected signal back from the target. The intensity of this LED should be maximized during target alignment while adjusting the "Sensitivity" knob very slowly.

5

10

The pulse signal on the connector marked "Output" provides a sharp leading edge for reliable and repeatable triggering of the connected device. This output has a low impedance (50 ohms) and is capable of driving a hundred feet of coax cable. Be sure to select the direction (0 to 5 Vdc or 5 to 0 Vdc) of this signal to provide the required polarity of the leading edge to properly trigger the connected equipment.

SPLS-5 Series - SPS with Remote Laser Sensor

The SPLS-5 consists of the SPS-IM Interface Module described on pages 6 and 7, an RLS-5P Remote Laser Sensor with eight foot cable and ¼-20 mounting bushing, and a R-5 (115 Vac), R-6 (230 Vac) or CA-SPS12 (5 to 15 Vdc) external power connection. One foot of T-5 Reflective Tape is also supplied.

NOTE: Be sure the power on the battery interface module is OFF before connecting the Remote Laser Sensor.

RLS-5P

The RLS-5P Remote Laser Sensor is capable of detecting a reflected pulse at distances of up to 50 feet [15 meters] and angles up to 75 degrees from a reflective tape target. In some applications, reflective tape is not required; the Laser Sensor will operate from contrasting colors. Due to the highly focused illumination provided by a collimated laser and the resultant narrow pulse returned to the sensor, it is critical that the Laser Sensor be carefully and securely mounted by means of the ¼-20 threaded bushing provided in order to achieve reliable results. This ¼-20 mounting bushing can also be used to ground the Laser Sensor.

Whenever possible, a 1/2" [13 mm] square piece of T-5 Reflective Tape should be applied to a clean area on the rotating object. The Laser Sensor should be mounted and optically aligned to illuminate the reflective tape target once per revolution. It is recommended that the

9

Controls

The "Power" switch on the SPS-IM controls both the operation and the charging of the system. The unit will only charge from external power in the power OFF position. In the power ON position, the unit will operate directly from external power any time that it is being supplied. Otherwise, it functions on internal battery power.

The "Output Selection" switch determines the polarity of the leading edge of the TTL compatible output signal. In the "NON-INVERTING" position, the output signal on the BNC connector will be a negative going 5 to 0 Vdc TTL pulse derived directly from the conditioned sensor output. When the "INVERTING" position is switch selected, the BNC output signal will be a positive going 0 to 5 Vdc, TTL compatible pulse.

Recharging the Batteries

To recharge the SPS-IM Interface Module batteries:

1. Connect the recharger/power supply or external power cable to the recharger input jack labeled "External DC".
2. Connect the recharger/power supply into a working ac outlet, or the external power cable to a dc power source of 5 to 15 Vdc.
3. Be sure the "Power" switch is in the OFF (CHARGE) position. The red "CHARGE" LED will indicate that the batteries are being charged. Allow 16 hours to fully charge.
4. Remove the charging source or move the "Power" switch to the ON position once the 16 hour charge cycle is completed.

NOTE: When not in operation, do not leave the SPS-IM continuously connected to a recharger/power supply or 5 to 15 Vdc external power for more than 16 hours as this may damage the batteries.

7

FUNCTIONS AND OPERATION

SPS Interface Module

The SPS Interface Module (SPS-IM) provides power to the input sensor, receives and processes the return pulse signal, and provides a switch selectable positive going 0 to 5 Vdc or negative going 5 to 0 Vdc TTL pulse train trigger output on a BNC connector. Connections and operation are common to all SPS models. Fully charged internal NiCad batteries will typically provide six to eight hours of continuous operation. In addition, the SPS system can be operated continuously on external power by use of the ac recharger/power supply or dc power cable provided.

NOTE: Before using, charge the internal NiCad batteries for a full 16 hours using the recharger/power supply or cable provided. See **Recharging the Batteries** section on page 7.

Connections

Connect the input sensor via the 1/8" [3.5 mm] phone plug to the mating connector on the SPS-IM. This sensor may remain connected even when recharging the internal batteries of the SPS-IM.

Connect the output signal cable to the BNC connector on the opposite end of the SPS-IM and to the external equipment to be triggered. If operating from the recharger/power supply, connect the recharger to the connector marked "External DC" and connect the wall unit to the appropriate power source. When using the CA-SPS12 cable to provide 5 to 15 Vdc, connect the Black lead to (+) and the Black with White Stripe lead to (-) dc power.

NOTE: When not in operation, do not leave the SPS-IM continuously connected to a recharger/power supply or 5 to 15 Vdc external power for more than 16 hours as this may damage the batteries.

6

SPS-5 SERIES - SPS With Remote Optical Sensor

The SPS-5 consists of the SPS-IM Interface Module described on pages 6 and 7, an ROS-5P Remote Optical Sensor with eight foot cable and mounting bracket, and a R-5 (115 Vac), R-6 (230 Vac) or CA-SPS12 (5 to 15 Vdc) external power connection. One foot of T-5 Reflective Tape is also supplied.

ROS-5P

When connected to the SPS-IM as described above, the ROS-5P illuminates the target with a visible red light from a high intensity LED and detects the reflected pulses from the rotating reflective tape target with an internal photo-detector. The ROS-5P Remote Optical Sensor is capable of detecting a reflected pulse from T-5 Reflective Tape targets at distances of up to 3 feet [1 meter] and angles up to 45 degrees from the target. The sensor is supplied with a set of two M16 jam nuts and a 90° angle slotted aluminum mounting bracket.

For most applications, a 1/2" [13 mm] square piece of T-5 Reflective Tape should be applied to a clean area on the rotating object. The sensor should be mounted and optically aligned to illuminate the reflective target once per revolution. It is recommended that the optical sensor be placed at a slight angle (approximately 10-15 degrees) from perpendicular, so that the sensor will detect only the reflected pulses from the target. The sensor should be at least 2 inches [50 mm] and no more than 3 feet [1 meter] from the target. The green LED On-Target Indicator on the ROS-5P will blink at the input frequency or be continuously illuminated when properly aimed.

Operating the SPS-5 as a triggering source

Once the ROS-5P input sensor is properly mounted and aligned, further connections and operation should proceed in accordance with the functions and descriptions under the SPS Interface Module sections entitled "Connections" and "Controls" on pages 6 and 7 respectively.

8

RELIABILITY DIRECT, INC.

2911 S. Shore Blvd., Suite 170 League City, TX USA 77573 Tel: 281.957.9283 Fax: 281.334.4255