



SKF TMTI 300 Thermal Imager



Instructions for Use

EU-DECLARATION OF CONFORMITY

We, SKF Maintenance Products,
Kelvinbaan 16, 3439 MT NIEUWEGEIN, The Netherlands,
declare that

Thermal Imager TMTI 300

has been designed and manufactured in accordance with:
EMC DIRECTIVE 89/336/EEC as outlined in harmonised norm for
Emission EN 50081-1, EN 55011 (B)
Immunity EN 50082-2, EN 61000-4-2, -3, level 3.
USA FDA Standard 21 CFR, Ch 1, Part 1040.10
and is provided with the European CE approval.

The Netherlands, June 2005



Ebbe Malmstedt
Manager Product Development and Quality

SAFETY RECOMMENDATIONS FOR TMTI 300

- Always read and follow the operating instructions.
- Do not expose the equipment to rough handling or heavy impacts.
- The equipment must not be used in areas where there is a risk for explosion.
- Never aim the laser beam into someone's eyes.
- Use of controls or adjustments or performance of procedures other than specified in these instructions may result in hazardous laser radiation exposure.
- Opening the housing of the measuring unit may result in hazardous laser radiation exposure and voids warranty.
- Do not expose the equipment to high humidity or direct contact with water.
- All repair work should be taken care of by an SKF repair shop.



Contents:

1	GETTING STARTED	5
1.1	CONTENTS	5
1.1.1	<i>TMTI 300 Thermal Imager parts</i>	5
1.2	CONNECTING TO POWER.....	6
1.2.1	<i>Using Battery Power</i>	6
1.2.2	<i>Using Mains Power Adapter</i>	6
1.3	CONNECTING THE TMTI 300 TO A 'POCKET PC'	7
2	ONE HAND OPERATION	8
2.1	TMTI 300 HANDLE	8
2.1.1	<i>Mounting the imager and Pocket PC onto the Handle</i>	8
2.1.2	<i>Removing the Imager from the Handle</i>	11
3	OPERATING THE TMTI 300 THERMAL IMAGER	12
3.1	COMPUTER HARDWARE	12
3.2	USING THE LASER POINTER	12
3.3	USING THE TMTI 300 THERMAL IMAGER WITH A 'POCKET PC'	12
3.3.1	<i>Setting up the 'Pocket PC' with the TMTI 300 Thermal Imager</i>	13
3.3.1.1	Installing the SKF TMTI 300 Imager software onto a 'Pocket PC'	13
3.3.1.2	Starting the SKF TMTI 300 Imager software.....	13
3.3.1.3	Reinstalling the SKF TMTI 300 Imager software onto a 'Pocket PC' from Flash Memory.....	14
3.3.2	<i>Operating the 'Pocket PC' with the TMTI 300 Thermal Imager</i>	14
3.3.2.1	Software Button Operations	15
3.3.2.2	Navigation/Action Button Operations	17
3.3.2.3	Snapshot Transfer from a 'Pocket PC' to a PC	18
3.3.2.4	Recommended 'Pocket PCs' for use with the TMTI 300.....	18
3.4	USING THE TMTI 300 THERMAL IMAGER WITH A PC	19
3.4.1	<i>Installation of software on PC</i>	19
3.4.2	<i>Operating SKF TMTI 300 Imager software</i>	19
3.4.2.1	Turning off Microsoft ActiveSync.....	20
3.4.2.2	Control Panel.....	20
3.4.2.3	Menus	21
3.4.2.4	Producing a Temperature Graph (live imaging):.....	22
3.4.2.5	Use of PC software with no Thermal Imager connected	23
4	OPERATING NOTES AND PRECAUTIONS	24
4.1	TEMPERATURE MEASUREMENT	24
4.2	GENERAL	24
4.3	CLEANING & PERIODIC MAINTENANCE	24
4.4	CALIBRATION	24
5	SPECIFICATIONS.....	26

1 Getting Started

This User Manual refers to the SKF Thermal Imager system type TMTI 300, for use with a 'Pocket PC', or a PC.

1.1 Contents

The tool case contains the following items;

- TMTI 300 Thermal Imager
- Battery holder with 4 x AA (LR6) alkaline batteries.
- 12 V mains adapter with 4 plug inserts.
- RS 232 Connection cable for PC
- Handle for one handed use of imager and iPaq.
- Cable for use between recommended HP iPaq's and TMTI 300
- CD ROM with software and instructions for use.

Inspect all items before use. Damaged items must not be used.

1.1.1 TMTI 300 Thermal Imager parts



Figure 1. Thermal imager parts

1. On/Off switch and Power LED
2. Laser pointer aperture
3. Lens
4. DC power socket
5. Laser pointer button.
6. RS 232 socket
7. Battery compartment

1.2 Connecting To Power

The TMTI 300 Thermal Imager operates from 4 x AA (LR6) alkaline batteries, or from AC mains power.

1.2.1 Using Battery Power

1. Turn the Thermal Imager off.
2. Slide battery cover off.
3. Carefully remove battery holder and insert batteries. Standard AA (LR6) alkaline batteries or rechargeable batteries can be used. The polarity of the batteries is shown on the holder.
4. Replace battery holder. Check the connector is positioned towards the centre of the imager.
5. Replace battery cover.
 - **Do not use a 9V (6LR61) battery.**

NOTE:

- 4 new alkaline batteries last approximately 8 hours.
- If the red power LED starts flashing, immediately replace the batteries.



Fig 2. Inserting batteries

1.2.2 Using Mains Power Adapter

1. Turn the Thermal Imager off.
 2. Connect the DC power socket.
 3. Attach the appropriate plug insert to the mains adapter.
 4. Plug the power supply into a mains socket.
 5. Switch on thermal imager.
- **CAUTION: When using AC mains, only use the power supply included with the TMTI 300. Other power supplies may damage the TMTI 300 Thermal Imager.**

NOTE:

- It is recommended that the SKF Thermal Imager (not the 'Pocket PC') should be switched on approximately 2 minutes before use. This allows the internal electronics to stabilise, to achieve optimum performance.
- The mains adapter is only for powering the TMTI 300. It will not recharge the batteries.

1.3 Connecting the TMTI 300 to a 'Pocket PC'

1. Make sure the TMTI 300 Thermal Imager software has been installed onto the 'Pocket PC', see Section 3.3.1.1
2. Connect the Pocket PC's RS232 serial synchronization cable into its socket and the other end into the TMTI 300 RS232 socket, see **Figure 3**.



Figure 3: *The TMTI 300 Thermal Imager connected to a 'Pocket PC', configured for two handed operation*

NOTE: The pocket PC must be purchased separately.

2 One Hand operation

2.1 TMTI 300 Handle

The TMTI 300 Handle allows one-handed operation of the unit. The imager is attached to the front of the handle. A 'Pocket PC' is securely fixed to the back. The handle is designed to accept most commonly used 'Pocket PC' models.

The serial synchronization cable can be concealed within the handle grip.

2.1.1 Mounting the imager and Pocket PC onto the handle.

The pictures below give a step-by-step guide on mounting the TMTI 300 imager and a 'Pocket PC' onto the handle.



1. Front view
2. Back view



- 1) Gently squeeze the handle grips and open the handle



2) Un-clip and remove the cable connector cover.



3) Connect the serial synchronization cable to the 'Pocket PC' and thread the other end of the cable from through the back of the handle.



4) Pull the cable through the handle then mount the 'Pocket PC' on the back of the handle. pull the spring loaded clip up to secure the 'Pocket PC'.



5) NOTE: The clip can be rotated to accommodate different Pocket PC models. The clip must not foul the On/OFF button.



6) Replace and Slide the cable cover into position



7) Remove the RS232 connector cover from the thermal imager. Connect the free end of the cable. Replace the cover



8) Line up the holes on the back of the imager with the pegs on the handle.



9) Push the imager down onto the pegs, so that it locks down into position.



10) Coil the cable and store in the handle. Close the handle grip.



11) This makes using the imager very simple for many applications!

2.1.2 Removing the Imager from the Handle.



3 Operating the TMTI 300 Thermal Imager

Described in this section are:

- The Hardware
- Using the Laser Pointer
- Using the TMTI 300 Thermal Imager with a 'Pocket PC'
- Using the TMTI 300 Thermal Imager with a PC

3.1 Computer Hardware

The TMTI 300 system is designed for use with a 'Pocket PC' or a PC. For use with a 'Pocket PC' the imager is connected via an RS232 serial synchronization cable. The standard cable for use with most iPaq's is included (see 3.3.2.4).

For a PC, use the RS232 serial cable included.

- The TMTI 300 Thermal Imager can be connected to a 'Pocket PC' via an RS232 serial synchronization cable, see Section 1.3.
- To use the TMTI 300 with an IBM compatible PC, the supplied RS232 serial cable is inserted into the socket on the bottom of the imager. The other end connects into a COM port on the PC. Operation with a PC is independent of the 'Pocket PC'.

3.2 Using the Laser Pointer

The Laser pointer is used to allow the operator to illuminate and identify the centre of the scene that the Thermal Imager is viewing.

The laser pointer illuminates the area of the scene that is viewed by the "default" temperature measurement pixel. This is the central point on the 'Pocket PC' display, which is indicated by a red circle in **Figures 4**.

The length of the laser bar gives an indication of the pixel dimension. For the TMTI 300 to give an accurate temperature reading, the minimum area of the scene being viewed must be a square that totally encloses the laser bar. Therefore, the laser pointer is a useful tool to determine the maximum viewing range of the TMTI 300.

3.3 Using the TMTI 300 Thermal Imager with a 'Pocket PC'

Most 'Pocket PCs' can be used with the TMTI 300 Thermal Imager. This section describes some of the basic functions of 'Pocket PCs' with the TMTI 300. These functions are common to many different available brands of 'Pocket PC's.

3.3.1 Setting up the 'Pocket PC' with the TMTI 300 Thermal Imager

3.3.1.1 Installing the SKF TMTI 300 Imager software onto a 'Pocket PC'

The TMTI 300 Thermal Imager can be used with most 'Pocket PCs', which have an RS232 serial port and run Microsoft 'Pocket PC' 2000, 2002, 2003 or MSWM 5, see Section 3.3.2.4 for recommended 'Pocket PC's. The 'Pocket PC' can be used to display, process and store snapshots of thermal images.

1. Ensure that ActiveSync is installed on your PC from the CD supplied with your Pocket PC, and that it is communicating with your 'Pocket PC.'
2. Refer to your 'Pocket PC' User Manual for more information on ActiveSync and synchronising your 'Pocket PC' with a PC. It is not necessary to create an ActiveSync synchronized partnership between the two. If you are given the option to choose between a "standard" and a "guest" partnership, select "guest".
Note: If you have difficulty connecting, go into the ActiveSync connection settings dialog screen and "check" both the 'allow serial' and 'allow USB' connection boxes.
3. Make sure the 'Pocket PC' is switched on, and connected to the PC.
4. Insert the supplied SKF TMTI 300 Imager software CD Rom into your PC's CD-Rom Drive.
5. On the PC screen, double click on 'My Computer' and then on the 'CD-Drive (D:)'.- 6. On the PC screen, double click on the folder "CE Install"
- 7. On the PC screen, double click on 'TMTI 300 CE setup.exe' to start the installation.
- 8. Follow the on-screen prompts, to complete the installation.

NOTE:

- While the Thermal Imager may be used solely with the 'Pocket PC', access to a PC is necessary for installing the Thermal Imager's software to the 'Pocket PC'.
- If the 'Pocket PC' has Flash memory or a memory card, the SKF 'Pocket PC' software will automatically be saved onto this memory during the initial installation.
- As an alternative to the portable use of the TMTI 300 using a 'Pocket PC', the output of the imager can be displayed and processed in real time using a PC, see Section 3.4 for using the TMTI 300 with a PC.

3.3.1.2 Starting the SKF TMTI 300 Imager software

1. Check that the 'Pocket PC' is charged.
2. Make sure the 'Pocket PC' is connected to the TMTI 300 Thermal Imager with an RS232 serial synchronization cable. This cable is either supplied with the 'Pocket PC' as a standard item or can be ordered from the 'Pocket PC' supplier as an accessory. A cable suitable for use with most iPaq's is included.
3. Switch on the 'Pocket PC' and the Thermal Imager.
4. Using the Stylus pen from the 'Pocket PC', select the **Start** menu and then select the **Programs** folder. Select the icon labelled "**SKF TMTI 300 Imager**".
5. Operation of the TMTI 300 Imager application is by means of the Navigation/Action button and software buttons. See Sections 3.3.2.2 for further information.

NOTE:

- The SKF Imager program takes a few seconds to load.

- If the 'Pocket PC' battery is allowed to fully discharge, the imager software will be lost and must be re-installed either from memory storage or from the CD again. The 'Pocket PC' uses power even when it is switched off. Regular recharging and transferral of images is therefore recommended.

3.3.1.3 Reinstalling the SKF TMTI 300 Imager software onto a 'Pocket PC' from Flash Memory.

The imager software can be re-installed from flash memory storage on newer Pocket PC's using File Explorer. For example on HP iPAQs, open "File Explorer", first select "My Device" from the drop down menu at the top of the screen, then select "iPAQ File Store" and finally "TMTI 300 Imager". Select "OK" to confirm re-installation.



3.3.2 Operating the 'Pocket PC' with the TMTI 300 Thermal Imager

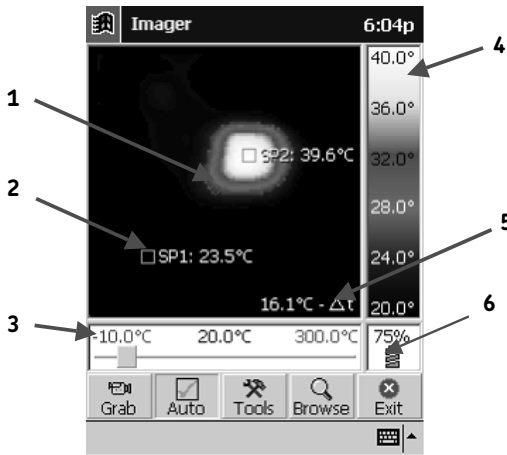

Figure 4: Screenshot of SKF TMTI 300 Imager 'Pocket PC' Software

1. Default Laser Pixel
2. Temperature cursor and temperature reading
3. Temperature range
4. Selected temperature range
5. Temperature difference between two selected temperature cursors.
6. Pocket PC battery indicator.

NOTE:

- For optimum performance the imager should be switched 'ON' and allowed to settle for about 2 minutes.
- If the 'Pocket PC' locks up then perform a soft reset of the 'Pocket PC'. Refer to your 'Pocket PC' User Manual for more information on Resets.

3.3.2.1 Software Button Operations

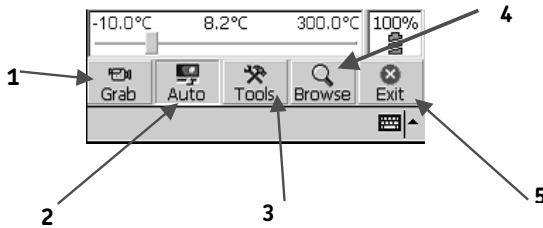

Figure 5: Buttons used within the SKF TMTI 300 Imager software.

1. Grab - takes a snapshot of the image
2. Auto - automatically adjusts temperature range and sensitivity
3. Tools - Allows the user to set a number of parameters (eg. Emissivity)
4. Browse - Allows the user to browse and delete saved snapshots
5. Exit - Closes down the SKF TMTI 300 Imager software

Grab

Takes a snapshot of the currently displayed image.

- The user is asked 'Do you wish to save this image?'
- Select 'Yes' or 'No'.
- No' will discard the snapshot and return to 'Live' mode.
- 'Yes' will save the image with the name 'Snapshot n.snp', where n is the next available number in the sequence starting from 1.

NOTE:

- All the setting and cursor functions may be applied to the grabbed image frames.
- Go to 'Browse' to view saved snapshots.

Auto

The Auto button can be set in the 'Tools' section to operate in two different modes:



- "Ticked box" Continuous Auto - Continuously adjusts the temperature range and sensitivity of the image for ease of viewing. In this mode the 'Auto' button can be used to switch Continuous Auto on or off.
- "Unticked box" Continuous Auto - The 'Auto' button is used in a one shot mode i.e. each time the button is pushed it will automatically adjust the temperature range and sensitivity for the present scene.
With Continuous Auto off, the image can be adjusted in a manual mode using the Nav/Action button, see Section 3.3.2.2 for more information.

Tools

Gives access to the following settings:

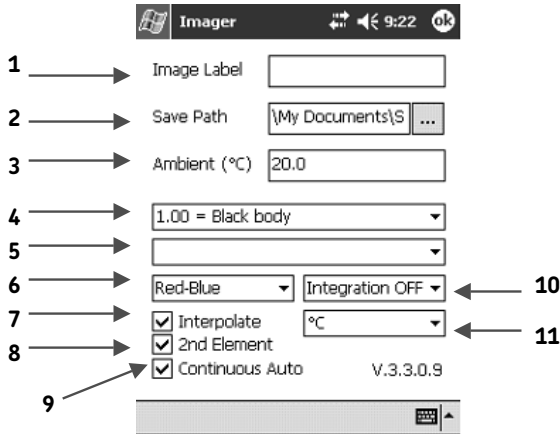

Figure 6: Tools menu within the SKF TMTI 300 Imager software.

1. Image Label – The user can enter a name for saved snapshots.
2. Image Folder – Defines the path directory to which snapshot images are saved .
3. Ambient (°C) – Sets the ambient temperature; if the emissivity (see below) is not given the value of 1 the software compensates for the ambient temperature to give more accurate temperature readings. Limited to 200°C if value entered is above 200°C.
4. Emissivity – Selects the emissivity for the material being imaged. Setting the correct emissivity value is important to achieve the accuracy of temperature readings, see note 3 in Section 4.1.
5. Calibration– Calibration file information.
6. Colour Map– Selects one of three possible colour options:
 - a. Greyscale
 - b. Red-Blue
 - c. Green-Blue
7. Interpolate – Selects a displayed resolution, of 16x16 pixels or 96x96 pixels.
8. 2nd Element – The user can select whether to have the second (SP2) temperature cursor displayed on the screen. see Figure 4.
9. Continuous Auto – See section on '**Auto**' above for further explanation.
10. Integration – The number of image frames to be integrated can be set to 'Integration OFF' or up to 10 frames. This function reduces “noise” on the image; it should be turned off when imaging a moving scene.
11. Temp. Units – Selects the temperature units displayed:
 - a. Celsius (°C)
 - b. Fahrenheit (°F)
 - c. Kelvin (K)

Browse

Gives access to five other buttons:

- Prev – Loads the previous snapshot file.
- Next – Loads the next snapshot file.
- Delete – Deletes the current snapshot. Dialogue box appears with, 'Are you sure? Yes/No'.
- Tools – Returns to the 'Tools' Menu, (see **Tools** above).
- Live – Returns to Live imaging mode.

Exit

Shuts down the SKF TMTI 300 Imager software application.

3.3.2.2 Navigation/Action Button Operations

All 'Pocket PCs' have a central Navigation/Action button. This is the only physical button used for operating the SKF TMTI 300 Imager software.

The Navigation/Action button can be depressed at five points and has five primary functions - U - up, D - down, L - left, R - right, S- select.

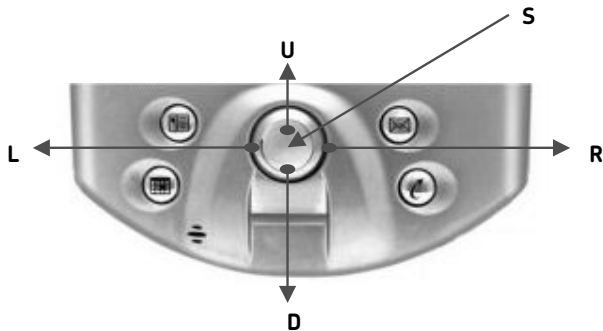

Figure 7: The Navigation/Action button of an HP iPAQ 5000 Series 'Pocket PC'

With 'Auto' adjust toggled OFF, pressing the centre S of the Navigation/Action button cycles through three options. The selected option is indicated by a flashing red outline surrounding the box. The three options are:

1. Manual control of the sensitivity and temperature range bar. This can be used in snapshot mode, or when 'Auto' adjust is toggled OFF.
 - The Sensitivity and temperature range of the displayed image can be manually adjusted by use of the Navigation/Action button. Pressing U or D adjusts the sensitivity and pressing L or R adjusts the temperature range.
2. Selected Temperature Cursor (SP1).
 - The SP1 cursor can be moved around the screen on the thermal image by using the Navigation/Action button, i.e. U, D, L, R.
3. Selected Temperature cursor (SP2).
 - The SP2 cursor can be moved around the screen on the thermal image by using the Navigation/Action button, i.e. U, D, L, R.

When the 'Auto' adjust is toggled ON, pressing the Nav/Action button will cycle between the two temperature cursors, and not the manual control bar.

3.3.2.3 Snapshot Transfer from a 'Pocket PC' to a PC

Microsoft ActiveSync must be installed to transfer Snapshot images from the 'Pocket PC' to a PC. Refer to your 'Pocket PCs' User Manual for more information on Microsoft ActiveSync.

To transfer a Snapshot file from the 'Pocket PC' to the PC, use this procedure:

1. Ensure that ActiveSync is installed on your PC and communicating with your 'Pocket PC.'
2. Refer to your 'Pocket PC' User Manual for more information on ActiveSync and synchronising your 'Pocket PC' with a PC.
3. On the PC, from the **File** menu in ActiveSync select "*Explore*". This will open a "Mobile Device" window. If the folder appears to be empty, select "*Refresh*" from the **View** menu
4. Double click on "*My Pocket PC*".
5. Double click on "*My Documents*" then select Snapshots, or click on the folder in which the snapshots have been saved. The folder in which snapshots are saved can be selected on the 'Pocket PC'; see **Tools** in Section 3.3.2.1. The snapshots will have extensions ".*snp*"
6. Copy the required Snapshots to a suitable folder on the PC (click and drag; or right click-copy then right click-paste into the folder).

NOTE:

- It is advisable to periodically download saved Snapshot images from the 'Pocket PC' to a PC. If a 'Pocket PC' battery runs flat, all saved images on the 'Pocket PC' will be lost, unless they are saved into Flash memory or onto a memory card (e.g. an SD card).

3.3.2.4 Recommended 'Pocket PCs' for use with the TMTI 300

This table is the current SKF view on 'Pocket PCs' which have been tested with the TMTI 300, as of March 2005. For an up to date list of recommended 'Pocket PC's, please see the SKF Mapro website, www.mapro.skf.com.

'Pocket PC'	Synchronizing cable
HP RZ1710	Autosync Cable. HP part number FA122A
HP iPAQ hx2000 series	Autosync Cable. HP part number FA122A
HP iPAQ H5100 & H5500 series	Autosync Cable. HP part number FA122A
HP iPAQ H4150 series	Autosync Cable. HP FA122A#AC3
HP iPAQ rx3700 series	Autosync Cable. HP part number FA122A
HP iPAQ hx 4700 series	Autosync Cable. HP part number FA122A
HP H2210	Autosync Cable. HP part number FA122A

It is necessary to acquire the appropriate synchronization cable for a specific 'Pocket PC'. For more information on synchronization cables it is advisable to contact your local manufacturer (e.g. HP) or supplier. A cable suitable for the HP "Pocket PC's" listed above is included with the TMTI 300.

3.4 Using the TMTI 300 Thermal Imager with a PC

The PC should be IBM compatible running MS Windows XP or 2000, with an RS232 serial port, USB port and 24 bit colour graphics. If a laptop PC is used, a TFT display is recommended. This application can be used for online imaging with the TMTI 300 connected to the PC or for analysis of snapshots previously saved on a 'Pocket PC'.

3.4.1 Installation of software on PC

The software is on the supplied CD-Rom.

1. Insert the supplied CD-Rom into the PC's CD-Drive (D:).
2. Double click on 'My Computer' and then on the 'CD-Drive (D:)'.
3. Double click on the "PC Install" folder.
4. Double click on 'TMTI 300 PC Setup.exe'.
5. Follow the on screen prompts to complete the installation.

NOTE:

- The SKF TMTI 300 Imager software will by default be installed into the following path:
 - C:\Program Files\SKF\SKF TMTI 300 Imager
- The above path and name can be changed during the installation, but it is advisable to leave it as the default. The installation will also put a 'Shortcut Icon' onto your PC's desktop to allow quick and easy start-up of the software.

3.4.2 Operating SKF TMTI 300 Imager software

Connect the Thermal Imager to the PC using the RS232 cable provided.

Launch the SKF TMTI 300 Imager program from the Desktop icon, or from:

- **START/PROGRAMS/SKF/SKF TMTI 300 Imager**

When launched, the window obtained will be similar to **Figure 8**.

On initial launch, if the Thermal Imager is not connected or switched on, the message "NO INCOMING DATA" will appear in the status box. The image window will contain the last viewed image, and the temperature displayed will be from the last viewed image.

On connecting the Thermal Imager to the PC and switching it on, the program will make connection with the imager (this may take several seconds).

On some PC's, after connecting the imager, it may be necessary to close the SKF TMTI 300 Imager application, and then reopen it. This allows the program to detect the COM port that the imager is using. The status box contains information on the settings of the imager, and the co-ordinates of the selected cursor whose temperature output is displayed in the temperature window.

3.4.2.1 Turning off Microsoft ActiveSync:

A common problem when communicating with the Thermal Imager is that the Microsoft ActiveSync program has “taken over” the available COM port. This may be rectified as follows:

1. Open the ActiveSync program (either by the Icon at the bottom right of the PC screen or from the Desktop).
2. From the **File** menu select “*Connection Settings*”.
3. “Un-check” the “Allow serial cable or infrared connection to this COM port” box, if already checked. If not required, the Ethernet box should be “Un-checked”.
4. ‘OK’ the Connection Settings window, and ‘Close’ the ActiveSync window.
5. Remember to “re-check” the serial cable connection box after use, if it is needed for other applications.

3.4.2.2 Control Panel

The Controls in the control panel are as follows:

- Sensitivity – see below for explanation.
- Range – see below for explanation.
- Resolution – sets the level of interpolation from 16 X 16 up to 128 X 128.
- Colour map – sets the display in greyscale, red-blue or blue-green.
- Orientation – the image can be rotated around to different orientations.
- Temperature Graph time scale – sets the temperature graph range.
- Ambient – set the ambient temperature.
- Emissivity – select a value to suit the object under examination, see Note 3 in Section 4.1.
- Calibration Set – The calibration file is displayed in this box.
- Temperature units – choose ° Celsius, ° Fahrenheit or Kelvin.
- Integration – sets the number of frames to integrate, up to ten maximum.

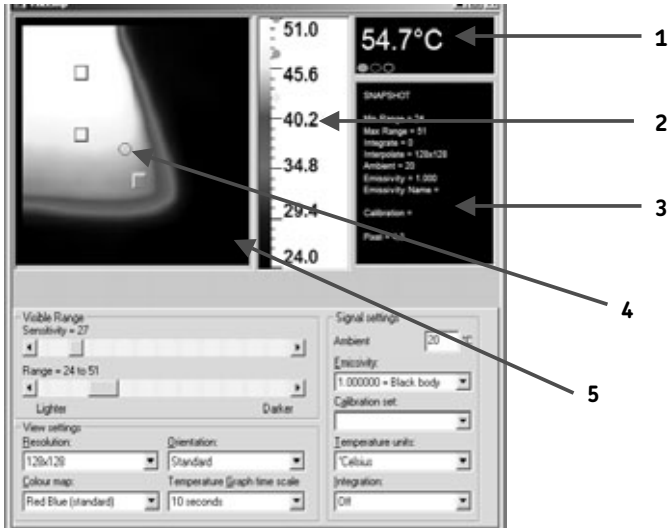

Figure 8: Thermal Imager launch window

1. Temperature display window
2. Selected temperature range
3. Status box
4. Laser default pixel
5. Image window

Adjusting the displayed Thermal Image:

- The sensitivity and range can be automatically adjusted for a single image by clicking on the 'Single Auto Gain' button. For continuous automatic adjustment the 'Continuous Auto Gain' button should be selected, this button is on the tool bar, see **Figure 9**.
- To use the manual controls whilst imaging live, it is necessary to first toggle off the 'Continuous Auto Gain' button. The horizontal scroll bars can be used to manually adjust the displayed image's sensitivity and range.
- The 'Sensitivity' number indicates how many degrees span the image from black (cold) to white (hot). The range numbers represent the upper and lower values of temperature from black (cold) to white (hot).

3.4.2.3 Menus

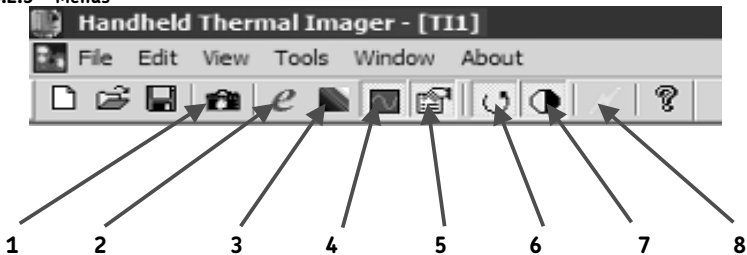

Figure 9: Thermal Imager Tool Bar

1. Take snapshot
2. Edit emissivities
3. Edit colour map
4. Toggle temperature graph
5. Toggle controls
6. Continuous auto gain
7. Single auto gain
8. Live display

The **File** menu allows the following:

- New – opens a new imager window, which may be set up to run under its own set of controls.
- Open... – opens a previously stored image.
- Close – closes the current window.
- Save – saves the current window as a scene data file.
- Save As... – saves the current window as a new scene data file.
- MS Excel output... – saves data in CSV format from the temperature/time graph ready for use in a spreadsheet. Output of either the selected pixel(s) or all pixels can be saved to MS Excel at a suitable up date interval.
- Snapshot n – A list of previously saved snapshots.
- Exit – Exits program.

The **Edit** menu allows the following:

- Copy (Ctrl C) – takes a copy of the image, it can then be pasted into another document e.g. MS Word.
- Copy to bitmap – copies image to a '.bmp' file.
- Snapshot – takes a snapshot of the image and saves it as a scene data file.

The **View** menu allows the following:

- Toolbar - Turn the Tool Bar on and off.
- Status Bar - Turn the Status Bar on and off.
- Control Panel - Turn the Control Panel on and off.
- Temperature Graph - Turn the Temperature Graph on and off.

The **Tools** menu allows access to:

- Emissivity editor – allows the editing of the emissivity tables.
- Colour map editor –allows the editing of the colour map editor.
- Edit Label – allows the editing of the labels for saving the images.

The **Window** menu allows access to the running windows and allows the user to control how they are displayed. The options available are:

- Cascade. – Cascades all open images
- Tile. – Displays all open images simultaneously.
- Arrange Icons. – arranges the Icons of minimised windows.

The **About** menu displays information about the program, including the software version number.

3.4.2.4 Producing a Temperature Graph (live imaging):

- Use the 'temperature graph toggle' on the Tool Bar, or select Temperature Graph from the **View** menu. See **Figure 9** for more information on the Tool Bar.
- The displayed window layout with temperature graph will look like **Figure 10**.
- The time axis of the graph can be adjusted by selecting values from the "Temperature Graph time scale" function in the controls window.

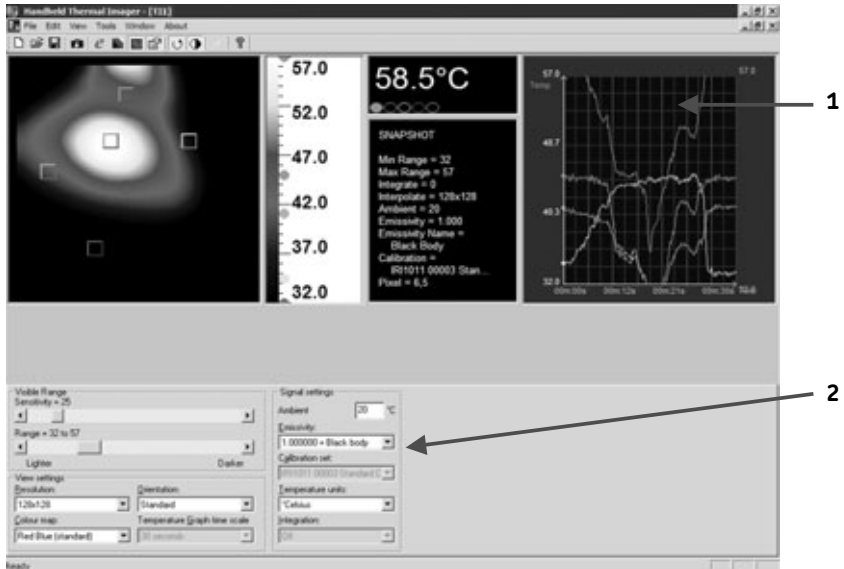

Figure 10: Image display, control panel and temperature graph.

1. Temperature graph
2. Control panel

The window may be re-sized to optimise viewing of the display and status display.

Temperature measurement cursors can be added (and removed) from the image by “double clicking” the mouse cursor over the desired part of the image. Up to 10 cursors can be selected and each one is displayed in a different colour. To read the temperature of a cursor, use the mouse to click on the corresponding oval colour as displayed in the “temperature display window”, see **Figure 10**. The temperature graph plots will also be displayed in the same colour as the selected cursors.

3.4.2.5 Use of PC software with no Thermal Imager connected

The software may be used to examine stored snapshots without the imager connected. When the program is launched, the image window should be closed. From the **File** menu, select “*Open*” and a list of saved ‘.snp’ files will be available from the last folder saved to.

Select the required ‘.snp’ file and the image will be presented in a window with all the status data from when the scene data was recorded. The information in the image window may be manipulated as for live images, except that a temperature graph will not be available, integration of multiple images will not be possible and the continuous auto gain function is not required.

4 Operating notes and precautions

4.1 Temperature measurement

The following should be noted when using the instrument as a temperature indicator:

1. The indicated temperature value is derived from a calibration obtained when the instrument is in a thermally stable environment. If the instrument is not thermally stabilised, there may be an error in the indicated temperature. Thermal stabilisation may take a few minutes – a period of 2 minutes or longer may be necessary.
 2. The calibrated temperature output is the figure in the temperature box; the temperature scale and display colours are indicators only.
 3. Caution should be observed in using the emissivity control – the user should explore the effect on the observed temperature of an object when different emissivities are selected. Figures associated with particular materials are supplied as a guide only. Low values of emissivity should be used only with extreme caution as large errors in temperature readings may be obtained with only small errors in emissivity.
 4. Only the central 12 x 12 elements should be used for temperature measurements. The camera should be positioned so that the item of interest appears within this area of the display.
- **Caution: Do not adjust the lens focus. The lens is fixed focus and factory set.**

4.2 General

The lens and associated holder is not user adjustable. The focal point of the imager has been set at manufacture according to specification. SKF will not be held responsible for any internal damage should this mount be altered. Behind the lens is the accurately positioned chopper blade.

4.3 Cleaning & Periodic Maintenance

Only when necessary, clean the lens using a soft dry lint free cloth and isopropyl alcohol. The body of the imager can be cleaned using a moist cloth. Do not use solvents for cleaning. When in storage for more than a month, the batteries should be removed.

4.4 Calibration

One of the main costs in manufacture imagers is calibrating and specifying the accuracy of the imager. In order to reduce this cost, SKF have decided to concentrate on the application of predictive maintenance, where the primary requirement is to identify hot spots and get an indication of the temperature rise over ambient, or a comparative temperature rise with a similar component. With a sensitivity of -0.3°C , the imager is suitable for this application allowing good detection of hot spots and temperature differences. Consequently SKF supply the imager without a defined accuracy.

For the SKF TMTI thermal imager, a more appropriate annual check is a conformity check. This would involve a black body to check the instrument's ability to distinguish temperature differences and a general operational check.

5 Specifications

PERFORMANCE

Temperature Measurement
range: -10°C to +300°C
Field of view (FOV): 20° x 20°
Spectral Response: 8 to 14 micrometers
Sensitivity: ~0.3K @ 30°C
Displayed Image: 96 x 96 pixels
Detector: 16 x 16 pixel array
Frame rate: 8Hz

IMAGE STORAGE

Up to 1000 images per MB of Memory.

LASER POINTER

Class II laser

IMAGER POWER SUPPLY

Battery: 4 x AA (LR6) alkaline batteries.
Operation time: Up to 8 hours.
AC operation: AC adaptor, supplied.

MECHANICAL

Housing: Impact Resistant Plastic.
Dimensions: 120mm x 125mm x 80mm.
Weight: < 600g not including 'Pocket PC' and handle.
Mounting: Handheld & Tripod mounting.

TMTI 300 INCLUDES

Imager, software for 'Pocket PC', & PC, iPaq type synchronization cable,
2m RS232 connection cable - imager to PC, user
manual, AC power supply, Tool case.

ENVIRONMENT

Temp. operating range: -5°C to +50°C Humidity: 10% to 90% non condensing
Temp. storage range: -20°C to +80°C CE Mark (Europe): Complies with EMC directive
IP Level 40

COMPUTER REQUIREMENTS

Pocket PC: Compatible with most 'Pocket PC' devices running Microsoft 'Pocket PC' 2000, 2002, 2003 and MSWM 5. RS 232 to 'Pocket PC' communication cable or CompactFlash RS 232 adaptor where applicable.

PC: IBM compatible running MS Windows XP or 2000, with an RS232 serial port, USB port and 24 bit colour graphics.

All brands and product names are acknowledged and may be trademarks or registered trademarks of their respective holders.

- In line with our policy of continuous development of our products we reserve the right to alter any part of the above specification without prior notice.

Although care has been taken to ensure the accuracy of this publication, SKF does not assume any liability for errors or omissions.

- Conformement a notre politique de developpement continu de nos produits, nous nous reservons le droit de modifier, sans preavis, tout ou partie des specifications ci-dessus.

- Gemas unserer Firmenpolitik der standigen Weiterentwicklung unserer Produkte behalten wir uns Anderungen der obigen Daten ohne Vorankundigung vor.

- En linea con nuestra politica de constante desarrollo de nuestros productos, nos reservamos el derecho a modificar cualquier parte de las especificaciones sin previa notificacion.

- In linea con la nostra politica di sviluppo continuo dei prodotti ci riserviamo il diritto di apportare modifiche senza preavviso a qualsiasi parte della presente documentazione.

- I linje med var policy for kontinuerlig utveckling av vara produkter forbeholder vi oss ratten att andra ovanstaende specifikationer utan att meddela i forvag.

- In verband met onze politiek van continue ontwikkeling van onze produkten, behouden wij ons het recht voor om de specificaties van de vermelde onderdelen te wijzigen zonder nota vooraf.

- Em linha com a nossa politica de desenvolvimento continuo dos nossos produtos, reservamo-nos o direito de alterar este catalogo sem aviso previo.

- I overensstemmelse med vor politik for kontinuerlig udvikling af vore produkter forbeholder vi os ret til at andre pa hvilken som helst af de i brochuren navnte specifikationer, uden at meddele dette i forvejen. Desuden tages der forbehold for eventuelle trykfejl.

- Tavoitteenamme on tuotteidemme jatkuva kehittely. Pidatamme siksi oikeuden etukateen ilmoittamatta muuttaa ylla olevia erittelyja.

- Σύμφωνα με την πολιτική της συνεχούς ανάπτυξης των προϊόντων μας, διατηρούμε το δικαίωμα να αλλάξουμε οποιοδήποτε μέρος των παραπάνω χαρακτηριστικών χωρίς προειδοποίηση.

