



Instruction Manual

FCX 2000



LIST OF CONTENTS		page
1	Safety notes	20
1.1	Operation in hazardous areas	20
2	Introduction	20
3	Ex-data	21
4	Technical data	21
4.1	Operating data	22-23
5	Accessories	23
5.1	Controls and sockets	24
6	Operating instructions	25
6.1	Safety instructions	25
6.2	Putting into operation.	25
6.3	Choosing an operating mode	25
6.4	Replacing rechargeable batteries	26-27
7	Functions	28
7.1	Measuring frequencies	28
7.2	Predetermining frequencies	28
7.3	Counting pulses.	29
7.4	Predetermining pulses	29
7.5	Measuring levels	30
7.6	Predetermining levels.	30
7.7	Measuring periodic times	30
7.8	Predetermining periodic times	31
7.9	Measuring speed	31
7.10	Counting revolutions	32
7.11	Testing NAMUR initiators.	32-33
8	Calibration data.	33
9	Malfunctions and inadmissible stress	33
10	Repair	33
11	Guarantee	34
12	Liability	34

1. SAFETY NOTES

This operating manual contains informations and precautionary instructions which are to be obeyed, so that safe operation will be guaranteed under any condition described in here.

1.1 OPERATION IN Ex-DESIGNATED AREAS

The ECOM calibrator FCX 2000 is suitable for short-term measuring and simulation in intrinsically safe circuits of the categories ia or ib.

Short-term operation means, that any stationary use of the instrument is strictly forbidden.

The FCX 2000 in the operating mode "measuring" is an equivalent to a passive component without the storage of energy, i. e. it has no such qualities as capacitance and inductivity.

The highest ambient temperature must not exceed +40°C

Any maximum ratings for intrinsically safe circuits must be considered.

2. INTRODUCTION

The calibrator FCX 2000 is a portable explosion protected measuring and simulation instrument of high precision, mounted in a handy and robust casing. It is used for carrying out quickly and precisely most of all measuring and simulation functions that are needed for modern installations.

Main applications are the installation, maintenance, process start-up, determination of malfunctions, and the verification and calibration of process-control units in hazardous areas. Due to its precision, this instrument is suitable for inspecting installations that meet the quality standard ISO 9000. Immediately after switching on the FCX 2000 the display will show when the instrument got calibrated for the last time, and when it will be due for the next check-up. The instrument meets the requirements of both the standards, EN 50014 and EN 50020. It is available with ingress protection IP 54.

The electronic circuitry is housed in an robust metal casing, and great store is set by the protection of the instrument against faulty operation. For example the user will recognize through a four-line alphanumeric display, in which operating mode the instrument is working. Whether a signal is being predetermined or measured will be indicated immediately. Operating the FCX 2000 is very simple. Starting from the main menu, the user can call up all the different functions of the instrument by pressing just a key.

The FCX 2000 is powered by ordinary rechargeable batteries, e. g. 6 x 501 RS. For normal use and with fully charged batteries the operation time will last around 9 h. When the batteries start running low, and there is only a short reserve operation time left, a red LED will light up and indicate this fact. The entire functions of the instrument are microprocessor-controlled, and the use of the latest technology, like surface mounted devices (SMD) guarantee in addition of strict quality controls in our house the exceptionally high reliability of the FCX 2000.

3. HAZARDOUS LOCATION - DATA

Ingress protection: EEx ia IIC T6

EEx ib IIC T6

PTB-nr. Ex-92.C.2116

FCX 2000 as transmitter (in predetermining mode):

U_{max} = 10.5 V

JK = 14.1 mA

P = 74 m A

EEx ia IIC:

EEx ib IIC:

Ca ≤ 780 nF

Ca ≤ 3 μ F

La ≤ 10 mH

La ≤ 155 mH

FCX 2000 as measuring device (in measuring mode):

U_{max} = 55 V

JK = 485 mA

4. TECHNICAL DATA

Display: 4-lines, 16 alphanumeric symbols each

Discharge indicator: red LED

Supply voltage, internal: 6 x 501 RS rechargeable batteries

Battery change: outside hazardous area

Operation time: 9 h

Inputs: protected against unintended reversing of polarity

Outputs: short circuit protected

Operation temperature: - 10° C ... + 40° C

Storage temperature: - 10° C ... + 60° C

Reference temperature: 20° C ± 3 K

Air moisture: 0 ... 90 % relative humidity of the air

Ingress protection: IP 54

Weight: ca. 1000 gr.

Size: 185 x 105 x 45 mm (without probe)

Casing-material: aluminium

4.1 MODES OF OPERATION

Predetermining frequency

Range I: 0.01 Hz ... 99.99 Hz
Resolution: 0.01 Hz
max. fault: ± 0.01 Hz
Duty factor: 1 ... 99 %

Range II: 100 Hz ... 10 KHz
Resolution: 1 Hz
Fault: ± 1 Hz (100 Hz ... 1 KHz)
Duty factor: (at 100Hz) 1 % ... 99 %

Measuring frequency

Max. frequency: 25 KHz
Resolution: 1 Hz
Accuracy: 1 Hz
Resolution: 1 %
Accuracy: ± 1 % (upto 2 KHz)
Duty factor: readable

Frequencies < 2 Hz cannot
be measured in this mode.
It is possible in the Measuring
periodic time mode.

Measuring number of revolutions (probe)

Scanning principle: reflection of light
Scanning distance: 2 ... 20 cm
Range: 4 ... 50.000 min⁻¹
Resolution: 0.1 min⁻¹ (4 ... 999.9 min⁻¹)
1 min⁻¹ (1000 ... 2000 min⁻¹)
Accuracy: ± 0.1 min⁻¹ (4...999,9 min⁻¹)
Number of reflecting marks: 1 mark per measuring object

Measuring revolutions (NAMUR-initiator)

Range: same as probe
Resolution: same as probe
Accuracy: same as probe

Predetermining level

NAMUR: according to DIN 19234
Logic level: high approx. 8.8V/Ri = approx. 10 K
low approx. 0.1V/Ri = approx. 1 K

Predetermining periodic time

Range I: 0.001 sec ... 100 sec
Resolution: 0.001 sec
Accuracy: + 1ppm/K
Duty factor: 1 ... 99 %, adjustable

Range II: 0,1 msec ... 999,999 msec
Resolution: 1 μ sec
Accuracy: 1 μ sec
Duty factor: (at 999.999 msec) 1 ... 99 %

Measuring periodic time

Max. periodic time: 100 sec
Resolution: 0.1 msec
Duty factor: 1 ... 99 % readable
Resolution: 1 %

Predetermining pulse

Pulse time: 0.001 ... 100 sec
Pause time: 0.001 ... 100sec
Resolution: 0.001 sec
Number of pulses: 1 ... 10⁷
Faults: + 1ppm/K

Counting pulses

Counting range: 1 ... 10⁷
Max. frequency: 10 KHz
Min. periodic time: 1 μ sec
Counter reset: possible
Trigger: negative edge
Gate function: possible

Measuring levels

NAMUR: according to DIN 19234
Logic level: High > 2 Volt
Low < 2 Volt

ACCESSORIES

Measuring cable (red and black) connecting terminals, carrying case with belt, optional probe.

5.1 CONTROLS AND SOCKETS

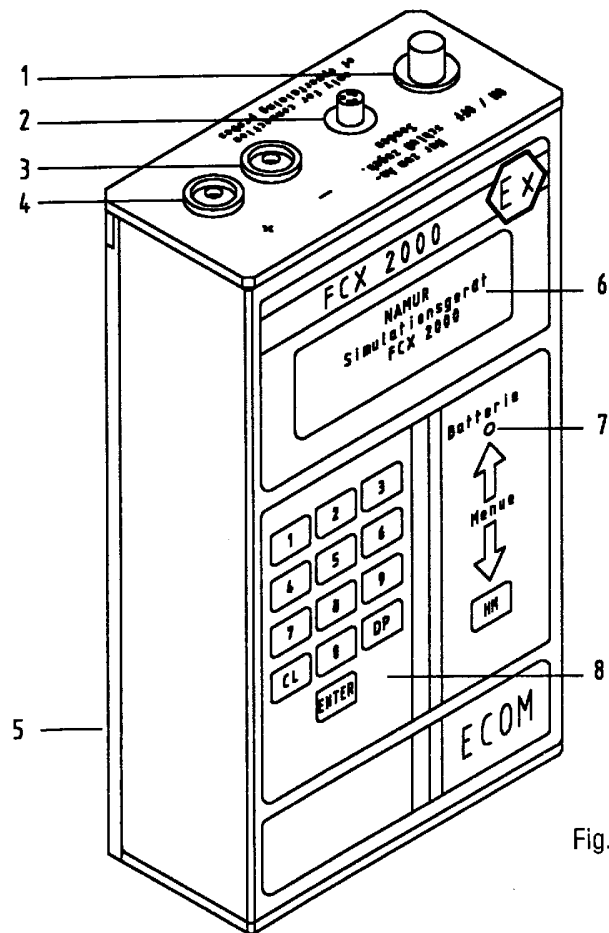

Fig. 1

- 1 ON / OFF - switch
- 2 Socket for the connection of an external probe
- 3 Signal socket (-)
- 4 Signal socket (+)
- 5 battery case
- 6 LCD - display
- 7 Battery discharge indicator (red LED)
- 8 Membrane keyboard

6. OPERATING INSTRUCTIONS

6.1 SAFETY INSTRUCTIONS

Using the FCX 2000 requires the strict observation of all safety instructions to avoid faulty operation.

The range limits which are defined in the instrument's technical data must not be exceeded.

The battery case must only be opened outside Ex-designated areas.

6.2 PUTTING INTO OPERATION

Press the ON / OFF - key.

For an instant the display shows "FCX 2000", and then turns to indicate "last calibration: ...".

The FCX 2000 is now ready to operate.

Pressing the ON/OFF-key a second time will then deactivate the equipment. ATTENTION! After turning off the instrument, there has to be a pause of at least two seconds before activating the FCX 2000 again.

6.3 CHOOSING AN OPERATING MODE

When turning the FCX 2000 on, and after a short time has elapsed, the display shows "last calibration: ...".

After pressing the ENTER-key, the first operating mode will be called up. By pressing one of the keys on the right hand side of the keyboard, marked with an arrow (ARROW-keys), all remaining operating modes of the instrument can be called up one-by-one.

(see fig. 2)

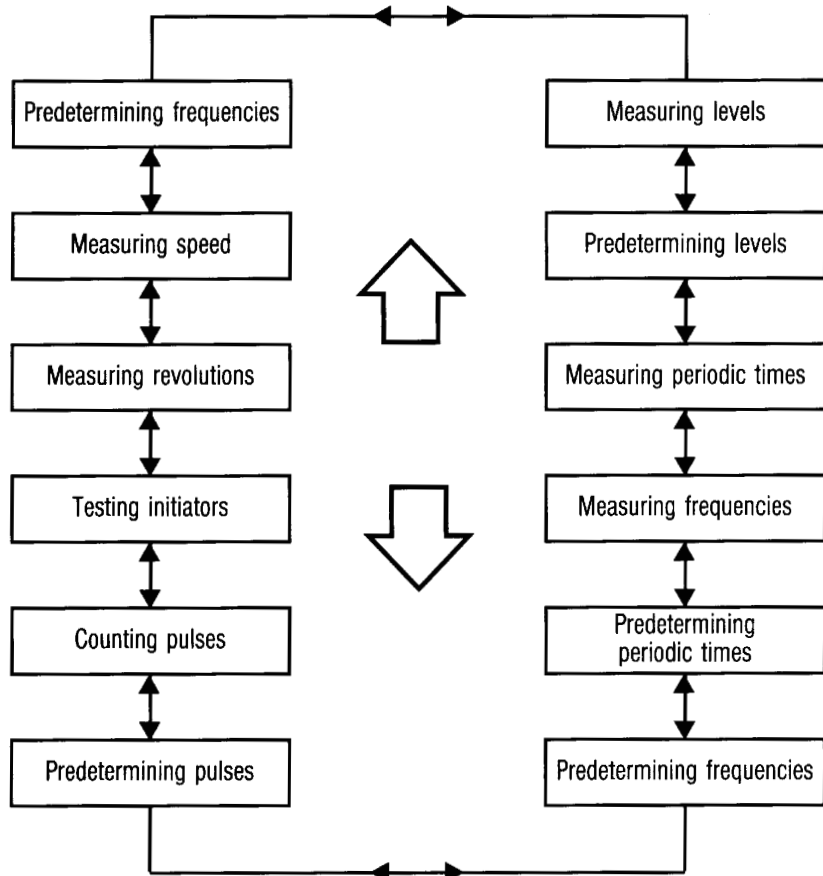

Fig. 2

6.4 REPLACING RECHARGEABLE BATTERIES

When the batteries start running low, and there is only a short period of reserve operation time remaining, a red LED will light up.

Now the batteries ought to be replaced, to guarantee further safe operation.

Replace batteries only outside the hazardous area.

When replacing batteries, it is to make sure, that only suitable batteries are being used.

The use of differing batteries is strictly forbidden.

To replace batteries remove the metal plate at the bottom of the casing (see fig. 3). This can be done by pushing aside the countersunk screw with the help of a suitable small hexagonal wrench. Loosen the lateral locking device and remove both covers. The battery case is now open, and flat batteries can be taken out by pulling the loose ends of the fabric straps on the inside of the case. Put the fabric straps back inside again, and insert new batteries.

Do mind the polarity, otherwise the instrument's function will be restricted. The bottom plate must be kept clean from foreign matter, like sand and dust. Closing the battery case follows the instructions given above, in reversed order.

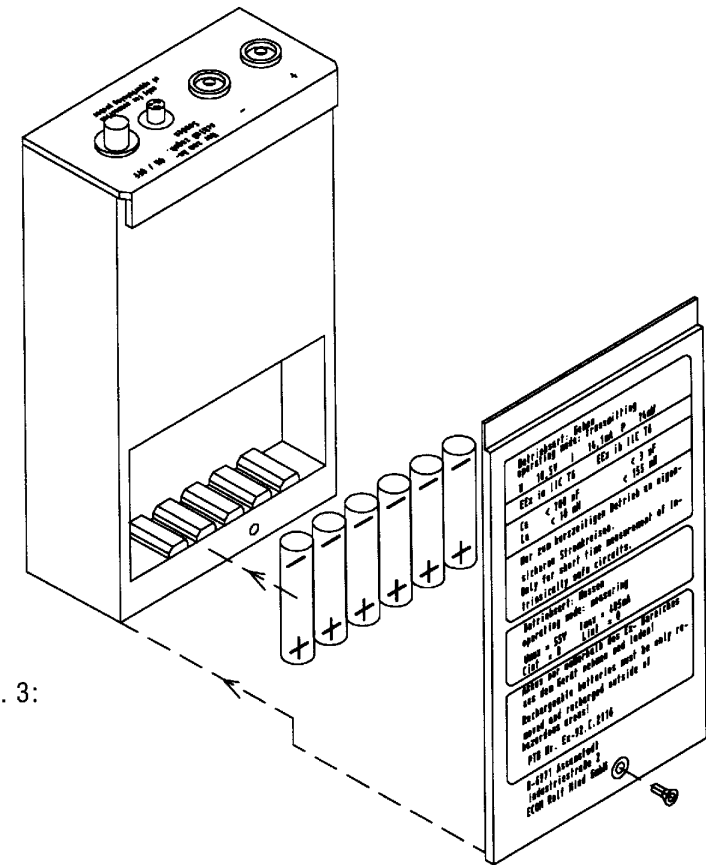

Fig. 3:

7. FUNCTIONS

7.1 MEASURING FREQUENCIES

- Connect the black measuring lead to the socket marked (-) and connect the red measuring lead to the socket marked (+).
- Adjust the operating mode "measuring frequencies" by pressing one of the ARROW-keys.
- Press the ENTER-key.
- Choose the signal form that is to be measured
key "1" for NAMUR-levels according to DIN 19234
key "2" for LOGIC-levels High > 2 Volt Low < 2 Volt
- Immediately after choosing the signal form the instrument is alive, shows the measured frequency (Hz), and the measured duty factor (%).
- By pressing the HM-key the measuring mode can be broken off.

7.2 PREDETERMINING FREQUENCIES

- Adjust the operating mode "predetermining frequencies" by using the ARROW-keys, and confirm this choice by pressing the ENTER-key.
- The frequency to be issued must be defined, the admissible range is visible on the display.
- Confirm by pressing the ENTER-key.
- Choose the signal form to be issued.
- Now the instrument is active, the display shows all chosen parameters and the predetermined frequency is being issued.
- By pressing the HM-key this operating mode can be broken off.

7.3 COUNTING PULSES

- Search the operating mode "counting pulses" by using the ARROW-keys.
- Confirm by pressing the ENTER-key.
- Choose the signal form to be measured.
- Now the instrument is active, it waits for pulses to come in, by pressing the key marked "▲", the process can be stopped.
- Starting again is possible by pressing the key marked "▼".

7.4 PREDETERMINING PULSES

- Search the operating mode "predetermining pulses" by using the ARROW-keys.
- Confirm by pressing the ENTER-key.
- Now define the pulse-duration time (ti), the adjustable range is visible on the display.
- Confirm by pressing the ENTER-key.
- Now define the pulse-pause-time (tp).
- Confirm by pressing the ENTER-key.
- Now define the number of pulses that have to be issued.
- Choose the signal form.
- The display shows all chosen parameters, you have now the possibility to alter the values again by pressing the CL-key.
- Pressing the ENTER-key will issue the pulses.
- The display shows an Xt-graph, at any time you can recognize how many percent of the predetermined number of pulses have already been issued.
- By pressing the HM-key the process can be broken off.
- At the end, the display will indicate the total number of pulses that have been issued, repeating the process may now be initiated.

7.5 MEASURING LEVELS

- Adjust the operating mode "measuring levels" by pressing the ARROW-keys.
- Confirm by pressing the ENTER-key.
- Choose the signal form that has to be measured.
- After this step, the display will indicate LOW- or HIGH-level of the adjusted signal form.
- Pressing the HM-key will break off the process.

7.6 PREDETERMINING LEVELS

- Adjust the operating mode "predetermining levels" by pressing the ARROW-key.
- Confirm by pressing the ENTER-key.
- Choose the needed signal form.
- Right after this step, the display indicates a HIGH- or LOW-signal.
- Pressing the ARROW-keys will switch to the opposite signal.
- Pressing the HM-key will break off the process.

7.7 MEASURING PERIODIC TIMES

- Press the ARROW-keys until the display shows "measuring periodic times".
- Confirm by pressing the ENTER-key.
- Choose the signal form that is to be measured.
- After entering the signal form, the instrument will be active.
- The measuring process can be broken off by pressing the HM-key.

7.8 PREDETERMINING PERIODIC TIMES

- Press one of the ARROW-keys until the display shows the operating mode "predetermining periodic times".
- Confirm by pressing ENTER-key.
- Now the required range must be predetermined.
- Slow processes that range within seconds need setting by pressing the key marked "1", fast processes need setting by pressing the key marked "2".
- The display will now show on its bottom line the maximum adjustment range in which the signals can be issued.
- Please insert the times you want and confirm them with ENTER.
- The value you entered into the instrument can be altered by pressing the CL-key.
- After this step, the duty factor has to be programmed, the admissible range for this will be shown on the display.
- Confirm with ENTER.
- Another correction of the time-value is possible by pressing the CL-key.
- Choose the signal form.
- The instrument is active, on the display the adjusted parameters are readable, a flashing cursor indicates, that the instrument is sending out pulses.
- Pressing the HM-key will break off the process.

7.9 MEASURING SPEED

- Adjust this mode by pressing the ARROW-keys, and confirm the adjustment with ENTER.
- Insert the diameter of the rotating part (mm) and confirm with ENTER.
- Insert the type of sensor that is being used.
- If a NAMUR sensor is being used, the instrument will be active right after actuation, if a probe is being used, the measuring button (on the probe) must be pressed first.
- After letting go of the measuring button, the speed will stay stored on the display, until the measuring button is activated again.

7.10 MEASURING REVOLUTIONS

- Adjust this mode by pressing the ARROW-keys.
- Confirm by pressing the ENTER-key.
- Choose a sensor type.
- If a NAMUR-sensor is being used, connect the (+) lead to the red socket on the instrument and connect the (-) lead to the black socket on the instrument.
- Pressing the key marked "1" will activate the instrument.
- If an optical probe is being used, press the key marked "2".
- Connect the probe to the one socket on the instrument, that is intended for this purpose.
- Fix a reflecting mark to the rotating object that is to be measured, before doing so, clean the object's surface from water oil and dust.
- Press the measuring button on the probe and hold it down, direct the visible red beam of light coming from the probe onto the rotating object, level with the reflecting mark. The distance between the opening in the probe and the reflecting mark should not exceed 200 mm. Mind a flashing or at faster revolutions a permanent indication of the pulse indicator.
- In case of surfaces that are reflecting themselves, such as shiny metal surfaces, direct the beam onto the surface under an oblique angle. Paint the surface black or the some other method to prevent unintended reflections coming from the object.
- After letting go of the measuring button, the number of revolutions will stay stored on the display until the measuring button is activated again.

7.11 TESTING INITIATORS

- Search this operating mode with the help of the ARROW-keys.
- Confirm your choice by pressing the ENTER-key.
- If there is no initiator connected, the instrument will indicate "initiator" ?
- Connect a NAMUR initiator the way, that the (+) lead is wired to the red socket and the (-) lead is wired to the black socket of the instrument.
- The instrument will indicate "please activate initiator".

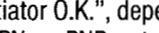
- The initiator has to be attenuated, to achieve this touch a steel object with the probe.
- The display shows: "  initiator O.K." or "  initiator O.K.", depending on the kind of initiator that is being use, either NPN or PNP output.
- After releasing the probe from the metal object, there now must be indicated on the display the opposite signal, compared to the indication before touching the object.
- Touching the metal object repeatedly allows to observe on the display the alternating signal of a functioning initiator.
- In case NAMUR initiator is malfunctioning, there are three different ways that this can be indicated on the display:
 - "short circuit"
 - "initiator?"
 - there is no alternating signal to be seen on the display if a metal object is touched repeatedly.

8. CALIBRATION DATA

After switching on the FCX 2000, the display will first show "FCX 2000" and then turn to "last calibration:..." and "next calibration:...". From these data the user will see when the instrument was calibrated last and when it will be due for another check-up. These data can be altered at all times with the help of a specific code that is only accessible to authorized personnel.

9. MALFUNCTIONS AND INADMISSIBLE STRESS

As soon as it is to fear that the equipment's safety has been impaired, the FCX 2000 must be taken out of operation and any unintended putting it back into use must be prevented. The instrument's safety for example can be impaired if

- there are visible signs of damage on its casing,
- the instrument was stored in an inadequate way,
- the instrument suffered damage from transport.

10. REPAIR

For any repair the conditions of ELEX V are valid. We recommend to have all repairs carried out in the manufacturer's factory, because for reasons of safety engineering the guard circuits have to be checked too.

11. GUARANTEE

The material and functionality of the FCX 2000 is guaranteed by us for a period of one year from the date of delivery. Claims can be made under guarantee by sending the defective unit to us. We reserve the right to repair, recalibrate or replace the unit.

12. LIABILITY

ECOM accepts liability for the provisions of the guarantee. No responsibility is accepted for damage, costs or losses arising from the use or purchase of the unit. ECOM will not be responsible for any special damages that occur or for consequential damages.

ECOM
INSTRUMENTS

ECOM Rolf Nied GmbH

Industriestraße 2 Telefon (0 62 94) 42 24-0
D-97959 Assamstadt Telefax (0 62 94) 42 24-90
E-Mail: ecom.sales@t-online.de

Internet: <http://www.ecom-ex.de>